



Fiddler's Rag



Vol. 48, Number 3
Celebrating 47 years

Santa Clara Valley Fiddlers Association
www.fiddlers.org

Mar 2020
Next Jam: Mar 1



President's Note

With rushing winds and gloomy skies, the dark and stubborn winter dies - Bayard Taylor.

We are all hoping for warmer weather to enhance each of our jamming experiences. March is on the way toward good weather with spring around the corner.

Check out our new signs! Admission, Slow Jam, Tune Exchange, and Bluegrass

Jam signs will help our newcomers find the events they are looking for. Of course, saying "Hello" to those unfamiliar faces adds that personal touch and may be the start of a new friendship.

Bev Tracey and Doug Judd are the newest trustees to join our board. Welcome to both of you. I look forward to working together to keep SCVFA strong and perpetuate traditional music.

Come find out about how SCVFA is organized at our Board meeting on March 18th. All members are welcome to join us at my home. We start at 5:30 with a short jam then enjoy a potluck dinner. The business meeting starts at 7:00. Contact me for details: [president \[at\] fiddlers.org](mailto:president[at]fiddlers.org).

Fiddle Frenzy at Graham Middle School, where our future stars play along with SCVFA members, is the next scheduled SCVFA performance. This gig is a benefit to introduce youth to fiddle music. It is my hope that it will bring more young musicians to join us every first Sunday. If you or anyone you know is having a celebration, let them know that SCVFA members are available to provide music at an extremely reasonable price. Member performances are an important source of fundraising for SCVFA. Payment for our music helps SCVFA keep our costs down. Contact: [Performances \[at\] fiddlers.org](mailto:Performances[at]fiddlers.org)

Thanks to Liz Alsop, John Alsop, Brigitte Curt and Susan Goodis (me) for leading Tune Exchange in February. Each of these members shared a tune with the

group. I encourage members to gather together and learn from each other.

Thanks to Dave Thomas for leading the slow jam. This jam is the best way for our newer musicians to learn to "play well with others". Music is provided or you can print a copy for yourself from our website: <https://fiddlers.org/tunes/>

Join us immediately following the March jam at Mountain Mike's Pizza for fun food and better conversation. Put down your instruments and get to know one another at "Afters". You'll be glad you did. 2011 Naglee Ave San Jose - just 0.6 mile and 1 minute away.

Volunteers are what keeps SCVFA going and it's fun! This is a great way to connect with more musicians and support our organization. It takes a village... Let's all do our part.

--- Susan

Member Directory Coming Soon!

The 2020 SCVFA directory is in the works. Please stop by the membership desk during the March jam to check your entries in the draft directory and let us know about any updates.



Show your pride in SCVFA, get your wearable and matching bumper stickers! Email [president \[at\] fiddlers.com](mailto:president[at]fiddlers.com) for information



In This Issue:

Page

President's Message.....	1
SCVFA Happenings	3
Jam photos.....	4-5
Column: Hicks' Licks: "Twin and Triple Fiddles" by Pete Hicks	6
Tune: "Close By" (2-part).....	7

The Fiddler's Rag is published monthly by the Santa Clara Valley Fiddlers Association and is provided to members of the Association. The Santa Clara Valley Fiddlers Association (SCVFA), founded in 1973 in San Jose, California, is a nonprofit, volunteer-operated organization dedicated to the preservation, teaching, and enjoyment of traditional music. The first membership in a household includes the Fiddler's Rag; additional members sharing the newsletter are steeply discounted. To join, sign up at the jam or see www.fiddlers.org/join.

Officers and Chairs

President-Trustee	Susan Goodis	News Editor	Patrice Tanti
Vice President	Dave Thomas	Newsletter Publisher	Doug Judd
Recording Secretary .	Jessica Ollmann	Performances Contact	Susan Goodis
Treasurer	Dinah Showman	Publicity	Dave Thomas
Membership Secretary	Pete Showman	Webmaster	Pete Showman

Trustees

Seat 1: Bev Tracey	Seat 3: Sam Schillace	Seat 5: Peter Forrest
Seat 2: Doug Judd	Seat 4: Dave Thomas	Seat 6: Cindy Dinga

To Contact the SCVFA:

Mail: P.O. Box 2666, Cupertino, CA 95015-2666
 Email to Susan Goodis: *president [at] fiddlers.org*
Newsletter Submissions & Comments: *newsletter [at] fiddlers.org*
Address changes: *membership [at] fiddlers.org*
 Website: **www.fiddlers.org**
 Copyright 2020, Santa Clara Valley Fiddlers Association

The Santa Clara Valley Fiddlers Association is a non-profit member-supported organization.

Donations to SCVFA are greatly appreciated and will assist in keeping traditional music alive by passing it on to the next generation.

Many local corporations offer matched donations for non-profits. Check with your employer... they may offer this benefit.

You can easily add SCVFA as a 501(c)(3) organization; our EIN is 51-0196154

Donate as you are able and traditional music will reap the benefits.

SCVFA wants musicians to know that we are “not just for fiddlers”. The image to the right side of the Fiddler's Rag name on page 1 includes a mandolin, a banjo, a guitar and a fiddle, to illustrate the diversity of instruments played at our jams and events.



Quote of the Month

“I think music in itself is healing. It's an explosive expression of humanity. It's something we are all touched by. No matter what culture we're from, everyone loves music.” — Billy Joel

KAMIMOTO
STRING INSTRUMENTS

“Fiddles for Every Style...”

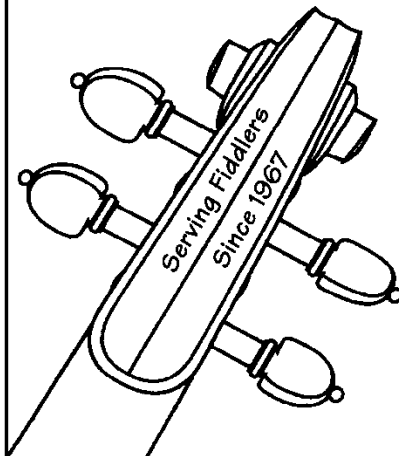

- New & Old Instruments
- Repairs & Restorations
- One-hour bow rehairing (by appt.)
- Rentals: Violin, Viola, Cello, Bass

Hours: Mon-Sat 10:00 - 5:30

[408] 298-8168
www.kamimotostrings.com

609 North Fourth Street
San Jose, CA 95112

[800] 892-3199

Fax: [408] 298-8198

SCVFA Happenings

SCVFA Slow Jam current tune list

www.fiddlers.org/learning/#slowjam

Angeline The Baker (D)	Red-Haired Boy (A)
Arkansas Traveler (D)	Red Wing (G)
Barlow Knife (G)	Shoo Fly (D)
Girl I Left Behind Me (G)	Soldier's Joy (D)
Jaybird (D)	Squirrel Hunters (A)
June Apple (A)	St. Anne's Reel (D)
Liberty (D)	Swallowtail Jig (E)
Mississippi Sawyer (D)	Whiskey Before Breakfast (D)
Over The Waterfall (D)	Wildwood Flower (C)

Thank you all for participating in the slow jam. The slow jam is for beginners who want to participate in a slow-paced jam (60-90 BPM).

Mark Your Calendar - Upcoming Events

3/1 1:00 – 5:00pm **Music Jam and Open Mike** at Hoover School and a special event: special bluegrass circle with Robert Cornelius.

SCVFA

Presents

Music Jam and Open Mike 2020

Sunday March 1, 2020

1:00 – 5:00 PM at Hoover School

Special Event:

Bluegrass Circle

with Robert Cornelius
of the Wildcat Mountain Ramblers

For information check the SCVFA website
www.fiddlers.org
or contact
president [at] fiddlers.org

BLUEGRASS

Robert Cornelius will lead a special event bluegrass circle at the SCVFA March 1st jam

Come out, bring an instrument, and have some fun!



Robert exudes joy and enthusiasm as he jams and performs. He currently plays banjo and/or bass with the Wildcat Mountain Ramblers, Wine Women and Wrong, Purple Mountain Majesty, The Brookdale Bluegrass Band, Tina Louise Barr and Friends and the Edgewood Mountain Boys as well as filling in with other bands as needed. Robert loves to jam and has led jam classes and also assisted Pete Wernick and others in hosting jam camps.

Annual Membership Meeting Highlights

As a quorum of members was present, President Susan Goodis convened the annual membership meeting of the SCVFA during the February monthly jam.

President Goodis then gave a “State of the SCVFA” message in which she mentioned the conversion to email publication of the Fiddlers Rag, which allows many colorful photos of jams and playouts. She talked about how we are a 501(c)(3), all-volunteer nonprofit organization, and she named many of the wonderful volunteers who do the many necessary jobs that make our monthly jams so much fun for all.

Elan Alford presented the two new trustee candidates: Bev Tracey and Doug Judd were elected unanimously by a show of hands to seats 1 and 2 respectively.

Special Feb. 2 Board Meeting Highlights

Following the annual meeting, trustees and officers held a board meeting. All officers willing to remain in office were re-appointed (see page 2 for updated list of Trustees, Officers and Chairs).

The next board meeting will be at Susan's home on March 18, with a potluck starting at 5:30PM. SCVFA members are welcome to attend.

Jessica Ollmann - Recording Secretary

February Jam Photos by Allan French, sketch photos by Susan Goodis



If you played at the SCVFA February jam, there is probably a sketch of you by Jim Smyth!



The Old-Time Rambler

MONTHLY

A Pretty Much Weekly Feature Brought to You by Geff Crawford

The Old-Time Rambler would like to present the following Old-Time Music Horoscope:

Pisces The Fish February 19 - March 20

With your piscine astrological identity you are clearly partial to fiddle tunes involving fish. High on your list are “Jeff Sturgeon”, “Pike’s Peak”, and “Soldier’s Koi”. You should definitely troll for more. Maybe try streaming.

Hook into new tunes every chance you get. Enjoy the lure of learning. Wait! Where are you going? I have more! What about “Roe, Roe, Roe Your Boat”?

March Jam Photos



Old time rocking on stage with Élan Alford, Dovie Wylie, Pete Showman and Dave Thomas (photo: Susan Goodis)



Charlotte Prater, Jay Keller and Dinah Showman (photo: Pete Showman)



John Alsop and his Nyckelharpa (keyed fiddle) on stage at the February jam. (photo: Pete Showman)



Hot bluegrass circle fueled by Pete Hicks (photo: Susan Goodis)

Hicks' Licks: Twin and Triple Fiddles

By Pete Hicks

This month we are presenting a solution to the problem of too many fiddlers at a jam. The answer is twin and three part harmony fiddling. You can harmonize instead of taking turns showing off to the other fiddlers. You can also get that wonderful Monroe multi fiddle sound and get to spend time with other fiddlers.

There are some basic rules to follow in harmony fiddle. The first is to make sure the melody (violin 1) is clear and strong. The melody rules the other parts. The harmony player is the slave to the melody player. If the melody is not clear, the harmony player will have nothing to base their playing on. I think that the melody should be a little louder than the harmony as well, but that is a personal opinion.

The second rule is simplicity. Simple musical phrases played in harmony can make your hair stand up. This month's music is a classic example. The solo is based on one simple phrase repeated and shifted up. In this kind of fiddling, use standard kick-offs that everyone knows, and warn the other players which one you will employ. The same holds true for doing fills and endings. A quick huddle before the song starts can help the fiddlers really come out looking good.

How do I know what to play? Harmony fiddling is just like harmony singing. If you sing harmony already, and can sing what you play, just play what you would sing on your fiddle, treating the lead fiddle as the lead vocal. If you like musical theory, here we go. There are three harmony parts just as there are three notes in any standard chord. The melody can be placed in the middle with a tenor part above and a baritone part below or the parts can be flipped around or inverted, hence the term chord inversions. With two fiddles, the usual practice is melody below and harmony a third above. When the melody is on C (in the key of C), the tenor part is on E. If the melody is on an F note, the tenor would be on an A, etc. Occasionally, there are choices to make in the tenor part, in cases where a fourth interval is used instead of a third. In the kick-off of Close By, the fourth interval indicates an A chord, where thirds would imply an E chord. Let your ear decide these issues, trying it both ways and picking the most pleasing.

Fills: fills can be twinned, or the fiddlers can take turns doing fills. Make sure that two fiddles are not filling at the same time if they are not in harmony or unison. This really muddies up the music and irritates the singers and even the banjo player. Be tasty.

Endings: use a nice standard ending lick to finish off the solo. Make sure the last notes are in harmony with a clear stroke.

Tenor Fiddling: the hard part of twin fiddling is usually the tenor part, as it requires proficiency in the higher registers of the violin. It is necessary to become comfortable in third and fourth positions to execute some tenor parts. Here are a few tips to help with this. When possible, use an open note to check intonation. In the third position lick in Close By, for example, (Meas. 5) hold your first finger on the A note (1st string) and play the open A with it on the 2nd string.

Another trick is using an open note to give you time to shift positions. If you are in third position in G, for example, any open string can be used to help shift. From High D, play B, A, G (3rd) open E, and 1st position D, B, A, G.

Practice your scales and arpeggios in high positions until you get over the sheer terror of trying them in public. You can also figure out the harmony parts to your versions of fiddle tunes and songs. Most of us play in a standard manner, and if you can harmonize to yourself, you can harmonize with others.

Baritone Parts: the baritone fiddle is the 3rd part. It is used when there are already two fiddles. The baritone plays the note that remains of the chord. Learning to do baritone parts is very difficult at first. To learn to hear this part, I suggest learning to sing baritone parts of standard songs. Have a baritone singer teach you some parts. Soon you will develop an ear for the low part. By themselves, these parts often sound strange, but with the other two parts, fantastic. Applying this to the fiddle learn the melody well first and then figure out note by note what the baritone part should be. It will be a third or fourth below the lead, depending upon what chord is being played or where we happen to be in the scale. If it is not one note, it has to be the other. At the end of a phrase, the baritone note must be a chord tone below the melody. In C, if the melody ends on C, the baritone ends on G; if it ends on an E, the baritone is C, etc. Very often in baritone singing or fiddling, we can't seem to find the right note. When this happens, try staying on the same note. Sometimes the other parts move while the baritone stays the same. You will find that there are often different ways to play a baritone part. When this happens try each and pick the best sounding. It is very often the simplest that sounds best. As an exercise, figure out the baritone part on Close By.

Phrasing: the melody part needs good clear phrasing, and leads the other fiddles. The tenor and baritone fiddles must follow the phrasing of the lead part. If you want to control the phrasing, play the lead part. To follow the phrasing of the lead fiddle, the tenor and baritone must listen and watch carefully.

(Continued on page 8)

Close By

(Melody + Tenor Harmony)

Bill Monroe & Robert Van Winkle
Arr. Pete Hicks

♩ = 100 A Major

* Alternate measure 12:

pss 11/14/07

Santa Clara Valley Fiddlers Association
P.O. Box 2666
Cupertino, CA 95015-2666



SCVFA Jam on the first Sunday of each month.
Location: Hoover Middle School, 1635 Park Ave.,
San Jose. The school is at the corner of Naglee and
Park. Cafeteria parking is on the Naglee side.

**Next Jam: Sunday March 1st,
1-5 pm at Hoover Middle School**

**Damaged or Missing Issue? Call us,
or email to: newsletter [at] scvfa.org**

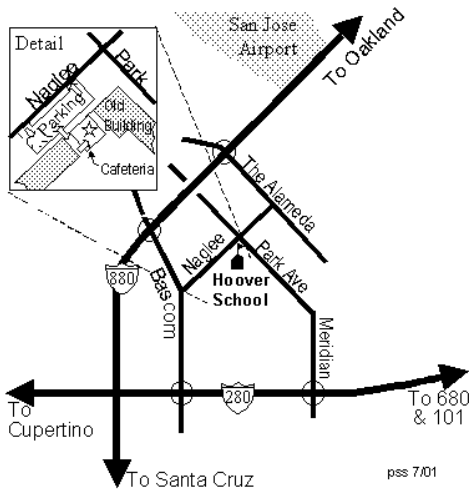

Continued from page 6

Follow the leader's bowing as well. In Mariachi groups, the lead violin is on the left, so that the other players can see the bowing. So, have fun with twin and triple fiddles. The next time you run across a jam with a fiddler, see if they want to try some twin parts with you. Many thanks to Doug Holloway and Luke Abbot for their helpful ideas.



Pete Hicks led the bluegrass jam-group in January and February. Pete wrote a series of columns for the Fiddler's Rag between 2007 and 2010 about playing bluegrass fiddle. Following last month's re-run from November 2007, this column first ran in the December 2007 Fiddler's Rag. More to come!

You can see the two-part version of Close By on page 7, and listen to it at one of the URLs below (by tapping, clicking, or typing them into your internet browser). Thanks, Pete Showman!

- www.fiddlers.org/Tunes/CloseBy_v1.mid (melody)
- www.fiddlers.org/Tunes/CloseBy_v2.mid (harmony)
- www.fiddlers.org/Tunes/CloseBy_v1v2.mid (combined)