



Fiddler's Rag



Vol. 52, Number 04
Celebrating 51 years

Santa Clara Valley Fiddlers Association
www.fiddlers.org

April 2024
Next Jam April 7th



VP's Note

By Ray Chen

Hello, everyone!!

I hope you're all enjoying the warmer weather. It's a nice change from the cold, rain, and wind we've seen at the recent jams.

A fun time was had at the third Sunday jam. Susan wrote, "The young girl that was sitting on the ground came by because she heard wonderful music. Somebody lent her a guitar so she could join us. She had a really good time. I pulled up some music on my phone so she could find the chords."

The Sunday jam attendance was back up to normal, even though it was cold and it started to rain during the jam. The bluegrass jam moved inside but the old-time jam stayed outside (they're under an overhang) although some of them moved inside into the cafeteria later because it just got too cold.

I taught a few brave souls "Mike in the Wilderness", a really fun John Salyer tune in A. That was an experiment and what we learned was having a fiddle workshop at the same time that people are jamming is a bad idea because it weakens attendance at both.

There are enough players who have a definite preference for bluegrass or old-time that those two jams don't really compete with each other. And the Slow Jam doesn't compete with the other jams because it's geared for beginners while the other jams are more for non-beginners.

But we discovered that if you add a workshop into the mix, people have to choose between jamming or the workshop. If too many go to the workshop, the jams suffer. If too many people stay with the jam, attendance at the workshop is low. And if you have just enough players to have a good jam, you have problems no matter what happens.

So, unless there's a hue and cry for instructional workshops, we're going to stop doing them.

That, however, brings up the question of "What should we do to support our members?" Cliff Riggs



Third Sunday Jam at Michell Park (Susan Goodis)

put some thoughts down on behalf of the Board and we need your feedback. So, please read his writeup on page 4 and tell us what you think!

I also wrote up some thoughts about the newsletter. I've taken on the job of overseeing the website upgrade work in addition to what I'm already doing for the organization. That's more work than I can do. I really need help and the newsletter is probably the easiest way for people to help me and SCVFA. Please read the writeup on page 6 and think about whether you can help.

A final note – Bruce Molsky, the greatest old-time musician of his generation and arguably, the greatest old-time musician alive today, will be in Berkeley doing a solo concert. The venue is smaller than the Freight and intimate – a wonderful setting for an evening with Bruce – but the show WILL sell out and is likely to do so quickly. I strongly encourage lovers of old-time music to grab a ticket.

The Freight also has a wonderful weekend planned at the end of April for bluegrass lovers (*see page 3*).

Driving to Berkeley can be painful but events like these make it worth it. I hope to see you there!!

In This Issue:

Page

Vice-President's Note	1
SCVFA Happenings.....	3
March Board Meeting Highlights	3
Questions For Our Members by Cliff Riggs	4
Letter to the Editor	4
Jam Photos by Ray Chen and Pete Showman	5
Newsletter – Help Wanted! by Ray Chen.....	6
Tune / Video: Ducks on the Millpond	7

The Fiddler's Rag is published monthly by the Santa Clara Valley Fiddlers Association and is provided to members of the Association. The Santa Clara Valley Fiddlers Association (SCVFA), founded in 1973 in San Jose, California, is a nonprofit, volunteer-operated organization dedicated to the preservation, teaching, and enjoyment of traditional music. Membership includes electronic delivery of the Fiddler's Rag.

To join, sign up at the jam or see www.fiddlers.org/join-the-scvfa/.

Officers and Chairs

President-Trustee	Susan Goodis	News Editor	Ray Chen
Vice President	Ray Chen	Performances	Susan Goodis
Recording Secretary	Jessica Ollmann	Publicity	Susan Goodis
Treasurer	Dinah Showman	Webmaster	Matt Mathis
Membership Secretary	Pete Showman		

Trustees

Seat 1: Zakkai Melamed	Seat 3: Leslie Wu	Seat 5: Ray Chen
Seat 2: Michelle Tan	Seat 4: Danny Clark	Seat 6: Cliff Riggs

To Contact the SCVFA:

Mail: P.O. Box 2666, Cupertino, CA 95015-2666
 Email to Susan Goodis: [president \[at\] fiddlers.org](mailto:president@fiddlers.org)
 Ray Chen: [vp \[at\] fiddlers.org](mailto:vp@fiddlers.org)

Newsletter Submissions & Comments: [newsletter \[at\] fiddlers.org](mailto:newsletter@fiddlers.org)

Address changes: [membership \[at\] fiddlers.org](mailto:membership@fiddlers.org)

Website: www.fiddlers.org

Copyright 2024, Santa Clara Valley Fiddlers Association

The Santa Clara Valley Fiddlers Association is a non-profit member-supported organization.

Donations to SCVFA are greatly appreciated and will assist in keeping traditional music alive by passing it on to the next generation.

Many local corporations offer matched donations for non-profits. Check with your employer... they may offer this benefit.

You can easily add SCVFA as a 501(c)(3) organization;
 our EIN is 51-0196154

Donate as you are able
 and traditional music will reap the benefits.

SCVFA is for more than fiddlers. The image to the right side of the Fiddler's Rag name on page one includes a mandolin, a banjo, a guitar and a fiddle, to show just some of the many different instruments played at our jams and events.



Quote of the Month

"This is a fantasy fiddle tune. The part you fantasize is the fiddle." – Guy Clark

KAMIMOTO

STRING INSTRUMENTS

"Fiddles
 for
 Every Style..."

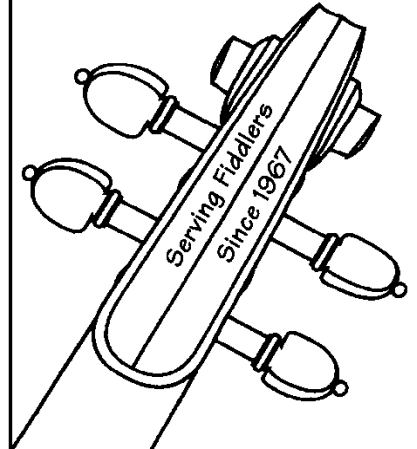

- New & Old Instruments
- Repairs & Restorations
- One-hour bow rehairing (by appt.)
- Rentals: Violin, Viola, Cello, Bass

Hours: Mon-Sat 10:00 - 5:30

[408] 298-8168
www.kamimotostrings.com

609 North Fourth Street
 San Jose, CA 95112

[800] 892-3199

Fax: [408] 298-8198

SCVFA Happenings

SCVFA Mission Statement

Santa Clara Valley Fiddlers Association (SCVFA) preserves traditional music genres that feature fiddle and other acoustic instruments. SCVFA takes pride in 'passing it on' to musicians and listeners of all ages and abilities.

Diversity Statement

SCVFA believes that our mission is fundamentally improved by diversity and inclusion. SCVFA is at all times committed to providing an open, safe, and welcoming environment for all our members and guests. We celebrate the varied abilities, ethnicities, sexualities, ages, gender identities, religions and cultural backgrounds of our community, and do not tolerate discrimination based upon these differences.

First Sunday Jam: April 7th 1:00 to 5:00 pm at Hoover Middle School. Suggested donation: \$5.00 – more or less as you are able. [Click here to donate online.](#)

Old-Time Jam: 1(ish)

Intermediate Bluegrass Jam: 1:30 – 5 pm led by Robert Cornelius.

Slow jam: 1:30-2:30 pm – Tunes are available on our [SCVFA website](#).

“AFTERS” Join us at Sam’s BBQ, 5:30 pm.
1110 S Bascom Ave, San Jose.

3rd Sunday Jam: April 21st, 1-3 pm
Shoup Park, 400 University Avenue, Los Altos

[Bruce Molsky Concert:](#) April 4, 7 pm

The master of old-time music is back with a solo show – fiddling, banjo, guitar, and singing. This WILL sell out. Hillside Club, Berkeley.

[Berkeley Bluegrass Festival:](#) April 26 – 28

Three days of concerts (with livestreams), jams, workshops and more! Freight & Salvage.

New OT Jam: 2nd and 4th Thursdays, 6-9 pm
Atlas Café, 3049 20th St (at Alabama) SF

[Irish Trad Music Driveway Concert:](#) Apr 10

Liz Knowles, Eamon O’Leary & Marla Fibish.
6 pm potluck, 7 pm concert. [SV House Concerts](#)

[Festival of Mandolins:](#) April 21, 12 – 5 pm

Croatian American Cultural Center, SF.

[CBA Music Camp \(Grass Valley\):](#) June 9–12

Nevada County Fairgrounds, Grass Valley

[Redwood Music Camp:](#) June 15-16

Monte Toyon Conference Center, Aptos.

March Board Meeting Highlights

By Jessica Ollmann

Our treasurer, Dinah Showman, presented our planned and actual budgets for the fiscal year that just ended as well as a proposed budget for the current year, which the trustees approved.

Ray Chen has taken over as project manager for our new website as we continue to try to get the website to fully function as intended and is looking for help with editing and assembling the newsletter.

The trustees reappointed officers to fill the roles of President: Susan Goodis; Vice President: Ray Chen; Recording Secretary: Jessica Ollmann; Treasurer: Dinah Showman; Membership: Pete Showman; News Editor: Ray Chen; Performances: Susan Goodis; Publicity: Susan Goodis; Webmaster: Matt Mathis. Dinah soon will be stepping down as treasurer, and we finally have a volunteer to take on the role.

The trustees are considering updating SCVFA’s financial account structure to make it more user friendly for the board and members without sacrificing security. Any update to our current restriction to payment by dual approval check will require a change in the bylaws, so proposed updates are in progress.

Leslie Wu will be stepping down as trustee, so the board will be looking to fill her seat.

Board members and officers will be reaching out to nursing homes and libraries in search of more paid playout opportunities.

The board continues to brainstorm about how to improve our jams and boost membership.

Questions For Our Members

By Cliff Riggs

Hello, fellow musicians!

During our board meeting on January 10th, we dedicated a significant portion of our time to reassess the goals of the SCVFA organization. It was crucial for us to ensure that our actions as board members align with the core purpose of our community.

Throughout the meeting, we reaffirmed our dedication to making SCVFA a hub for Old Time and Bluegrass musicians to connect, share, and jam together. We are committed to creating an inclusive environment where musicians of all skill levels can find a place.

Thanks to the support from our members through dues, jam donations, and various grants, we're in a strong financial position to back initiatives that further our mission.

Looking ahead, we're eager to hear your ideas and feedback on how we can enhance our support and broaden opportunities for more people to engage with the music we all cherish. While we've brainstormed a few ideas, your input is invaluable to us.

Here are some thoughts we've had:

- Introducing a member's jam finder/manager on our new website.
- Exploring additional outreach methods, such as college newspapers and radio stations. Should we also boost our social media presence to attract those seeking this kind of community?
- Organizing additional beginner jams outside the normal first Sunday events to help newcomers integrate and feel comfortable more swiftly.
- Considering the launch of our own workshops focused on specific tunes or instruments, tailored especially for beginners or young adults.
- Engaging professional and semi-professional musicians to lead jams.

We're keen to know your thoughts. What aspects are currently working well for you, and what improvements would you like to see in our jamming experiences? How should we approach reaching out to new musicians and those searching for a community to join?

Please share your ideas with any board member. Email us at [trustees \[at\] fiddlers.org](mailto:trustees[at]fiddlers.org) or find us at a jam.



Ray Chen teaching "Mike in the Wilderness" at the March Jam (Pete Showman)

Letter to the Editor

In the latest March issue, Susan and Ray wrote, "Payout" is the term coined by SCVFA that refers to community performances." Actually, the term was coined by Fritz Buell (president from March 1993 to May 2001). When he became president, he started the "payout" system because he said, "We had no reserves, no funds." That was described in the May 2012 Fiddler's Rag dedicated to Fritz and Marge Buell and describes their many contributions to the SCVFA.

Janet and I always enjoy reading the Fiddler's Rags to learn what the SCVFA is up to. Although moving in 2016 to El Cerrito (just north of Berkeley) was one of our best decisions, San Jose is just too long a drive for us to attend the monthly jams.

Thanks for keeping the SCVFA tradition alive,

Richard Brooks
(President from April 2008 to February 2016)

Editor – the organization owes a huge debt of gratitude to Fritz Buell who started the payouts and to everyone who's participated in payouts over the years. The payouts and member donations have put and keeps the organization on a sound financial footing. It's really hard to overstate how much they've meant to the organization!

Thank you, Fritz, Richard, and to everyone who's helped out over the years!

And we're sorry, Richard, that you and Janet are too far away but we're glad to hear from you, grateful for your continued support and interest, and very happy that things have worked out well for you!!

March Jam Pictures

By Ray Chen and Pete Showman



Newsletter – Help Wanted!!

By Ray Chen

The newsletter is a constant at SCVFA. From what I can tell, we've had a newsletter since the organization started.

You read that right – this newsletter is in its 51st year of publishing. I don't know if it was always published every month but we know it's gone out like clockwork every month for well over 20 years. One of the most important things in the newsletter is the information and reminder about the next jam. Before email and the internet, the newsletter was the only way to tell our members about the next jam. That works best if you send out *something* every month so I suspect that's what we did.

There were thoughts about moving away from the every-month schedule when I joined the Board. I spoke out strongly against that. Although I haven't come to the jams regularly until recently, I've been a member for many years. The monthly newsletter kept me somewhat in touch with you all and was a friendly and welcoming reminder that SCVFA was there and still going. We've heard this from other members too, who for some reason can't come to the jams anymore but want to stay connected to the organization. They enjoy reading the newsletter every month to see what's happening.

The thing is – putting out a newsletter every month is *hard*. A lot of work goes into the first page note, the articles, the pictures, the events, putting it all together, sending it out, and you don't ever get to take a month off.

It's the last thing – never having a break – that's the hardest thing now. My professional career also drummed into my head the principle that it's really bad if only one person can do the job. Everyone needs backup. People get sick, have to deal with emergencies, etc.

So, I'm looking for people to help me with that: people who are willing to assemble the newsletter a few (say 3-4) times a year. You don't have to write any articles or supply any original content unless you want to. This is just doing layout – putting the content together.

I already have one volunteer so if even one more person volunteers, we'll be sharing the load between at least three people and that will make things so much easier.

What do you have to do? Take articles, information, and pictures and put it into Microsoft Word. Move things around until you think they look good. Fix

any typos or grammar mistakes that you or our reviewers spot.

I have preset template files for the different page types (first page, last page, articles, Happenings, etc.). Word is (now!) good at generating pdf files and I use a free tool that combines all the pdf files together into the final newsletter in a few seconds.

Dealing with pictures is a bit more challenging than text but I'll have detailed instructions with screenshots so you can see exactly how it's done.

It takes me about three hours to put the newsletter together once I have all the content.

If you sign on, I'll show you the ropes. We can do some zoom training and work on an issue together before you take the lead on an issue. And the nice thing about there being more of us is if you run into problems, have a question, or just want to get a second opinion on something, we'll be there to help.

If you think you might be interested, reach out at *newsletter [at] fiddlers.org*. If you think you might be willing but aren't sure, reach out anyway. I'd be happy to chat with you and you can decide after that. You can always choose to give it a try and if it's too much, step back.

I hope to hear from you and let me close by saying that I've found working on the newsletter to be fun and rewarding. It's very satisfying to help the organization, and to put something out there and know that people read it and see it for years to come.

I hope to hear from you and look forward to working with you!



Dinah Showman, Treasurer and News Editor emeritus, working the front desk at the March Jam (Ray Chen)

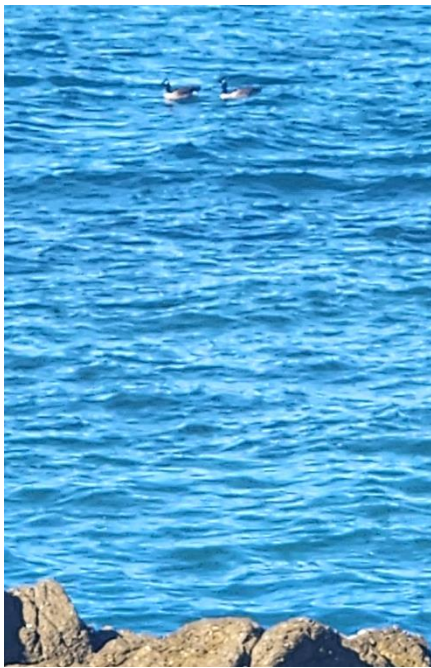

I was at Monterey recently and much to my surprise, I saw some geese on the ocean. Of course, the line “Ducks on millpond, geese on the ocean ...” came right into my head. There was no millpond nearby but I couldn’t keep myself from snapping a photo.

So, here’s some [“Ducks on the Millpond”](#), a classic Round Peak tune, brought to you by Eddie Bond on fiddle, Josh Ellis on banjo, Alice Gerrard on guitar, and Emily Mann on bass on stage at the 2013 Berkeley Old-Time Music Convention and the transcription is from the video. Enjoy!! (honk honk!!)

GDAE or ADAE

Ducks On The Millpond

Traditional
Transcribed by Ray Chen

Transcription copyrighted by Ray Chen. Permission is granted for personal and private instructional use only.

Measures 1, 5, and 1 with the parenthesized notes left out are all variations of the same idea. You can mix and match them as you like. Measures 3 and 7 can also be interchanged at will.



SCVFA
P.O.Box 2666
Cupertino, CA 95015-2666

**Next Jam:
Sunday April 7th
1-5 pm at Hoover Middle School**

The SCVFA Jam usually on the first Sunday of each month. Location: Hoover Middle School, 1474 Naglee Ave., San Jose. The school is at the corner of Naglee and Park. Cafeteria parking is on the Naglee side.

**Damaged or Missing Issue? Call us,
or email to: [newsletter \[at\] fiddlers.org](mailto:newsletter@fiddlers.org)**

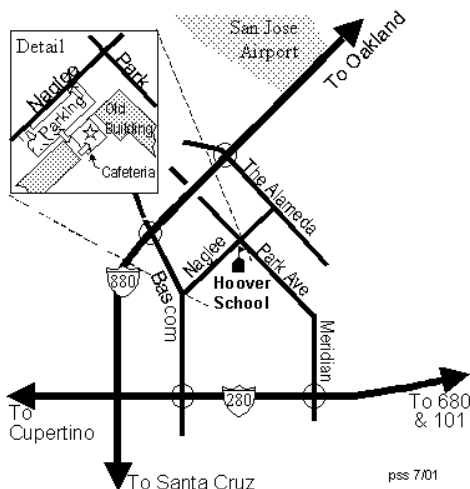

(below) March Bluegrass Jam - inside due to rain (Ray Chen)



Bluegrass Jamming Rules

- The leader chooses the next soloist and when to end. For songs, that's the person who sings the verses. For instrumentals, it's the person who kicks it off.
- Use signals to offer, accept, and pass on solos and to end the tune. Signals are body-language only!
- Pick tunes that people know or are easy to learn (easy key, standard chord progressions, simple lyrics).
- Don't use sheet music or an electronic device.
- The soloist is always right – if the soloist changes tempo or starts late, follow them anyway.
- Support the soloist. Give them room to be heard and to improvise by:
 - Playing quietly with basic, unsyncopated rhythm.
 - Not singing harmony on verses unless asked.
 - Not singing at all during instrumental solos.
- Listen to the music and watch for signals. The more advanced the jam, the more this matters.
- When in doubt, ask questions (but don't argue with the answers).