



Fiddler's Rag



Vol. 54, Number 03
Celebrating 53 years

Santa Clara Valley Fiddlers Association
www.fiddlers.org

March 2026
Next Jam March 1st



President's Note

By Ray Chen

Hello SCVFA!!

The February jam was well attended and the annual Members Meeting was a great success.

The highlights of the meeting were the election and leadership changes and listening to what members had to say about what they valued and wanted from SCVFA going forward.

On the leadership side, Susan Goodis officially stepped down from her position as Vice-President, Jennifer Kitchen was elected to a 3-year term as a Trustee, and Jennifer agreed to take over as Vice-President.

I want to thank Susan for her years of leading the organization as President and helping me as Vice-President. You'll keep seeing emails from Susan, though, since she will be continuing in her role of managing Publicity and Performances.

I'm also sad to announce that Danny "Hootenanny" Clark will be stepping down as a Trustee. He has apparently taken on way too many commitments and needs to cut back on a number of them. Unfortunately, and regretfully, SCVFA is one of them. I want to thank Danny for representing bluegrass and the bluegrass community. His perspective and experience will be sorely missed.

And yes, this means we have another open Trustee spot. Please let us know if you know anyone you'd like to recommend!!

The Board met shortly after the Annual Meeting to talk about what we heard. Based on what we heard, we'll be adding a slow(er) bluegrass jam and will try to add singing to the old-time jam. Lots of people were in favor of these. They're both things that can be done at the monthly jam that involve jamming, as opposed to sitting around and not jamming. And we can start these pretty much right away.

Jennifer Kitchen has volunteered to lead a Basic Bluegrass jam that will run from 1:30 to 3 pm. This jam will be different from the current Bluegrass Jam in that it will be focused on teaching traditional bluegrass.

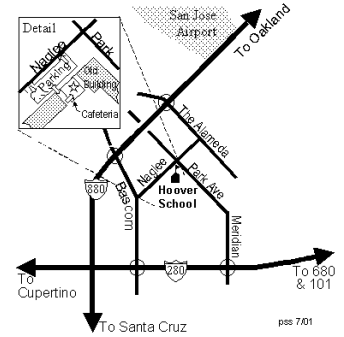

Jennifer has put together a songbook containing lyrics, chords, and pointers to reference recordings for twenty songs, and we've [posted the songbook](#) on the website. The jam will play only what's in the songbook. Eventually, more songs, as well as instrumentals, will be added to the songbook as the jam learns those tunes and are ready for more.

Jennifer will be limiting the songbook to well-known bluegrass standards. These are songs that most people who play bluegrass know. I'd say they're chestnuts except that many people keep playing and performing them.

I was at a show recently where the band played a lot of standards. They had to get a substitute bass player / singer at the last minute. So when they wanted 3-part harmony, they had to play tunes that the bass player knew well enough to sing harmony on. Many of those tunes were standards. The bass

(continued on page 6)

Future Playouts / Performances

We have numerous opportunities throughout the year. For more info visit: <https://www.fiddlers.org/open-band>
Currently nothing until June but that will likely change.

In This Issue:

Page

President's Note	1,6
SCVFA Happenings	3
Jan. Board Meeting Highlights by Jessica Ollmann	3
SCVFA at The Great 48 by Susan Goodis.....	4-5
Jam Photos by Ray Chen and Susan Goodis.....	7
Benefit Performance	8

The Fiddler's Rag is published monthly by the Santa Clara Valley Fiddlers Association and is provided to members of the Association. The Santa Clara Valley Fiddlers Association (SCVFA), founded in 1973 in San Jose, California, is a nonprofit, volunteer-operated organization dedicated to the preservation, teaching, and enjoyment of traditional music. Membership includes electronic delivery of the Fiddler's Rag.

To join, sign up at the jam or see www.fiddlers.org/join-the-scvfa

Officers and Chairs

President-Trustee	Ray Chen	News Editor / Publisher	Ray Chen
Vice President	Jennifer Kitchen	Performances	Susan Goodis
Secretary	Jessica Ollmann	Publicity	Susan Goodis
Treasurer	Bennett Amodio	Webmaster	Ray Chen
Membership Secretary	Cliff Riggs		

Trustees

Seat 1: Jennifer Kitchen	Seat 3: Susan Goodis	Seat 5: Open
Seat 2: Michelle Tan	Seat 4: Open	Seat 6: Cliff Riggs

Newsletter Reviewers: Pete Showman, Dinah Showman, Vicki Parrish, Susan Goodis, Jennifer Kitchen

To Contact the SCVFA:

Mail: SCVFA, P.O. Box 390235, Mountain View, CA 94039-0235

Email to Ray Chen: [president \[at\] fiddlers.org](mailto:president[at]fiddlers.org)

Susan Goodis: [vp \[at\] fiddlers.org](mailto:vp[at]fiddlers.org)

Newsletter Submissions & Comments: [newsletter \[at\] fiddlers.org](mailto:newsletter[at]fiddlers.org)

Address changes: [membership \[at\] fiddlers.org](mailto:membership[at]fiddlers.org)

Website: www.fiddlers.org

Copyright 2026, Santa Clara Valley Fiddlers Association

The Santa Clara Valley Fiddlers Association is a non-profit member-supported organization.

Donations to SCVFA are greatly appreciated and will assist in keeping traditional music alive by passing it on to the next generation.

Many local corporations offer matched donations for non-profits. Check with your employer... they may offer this benefit.

You can easily add SCVFA as a 501(c)(3) organization; our EIN is 51-0196154

Donate as you are able and traditional music will reap the benefits.

SCVFA was founded in 1973 to support fiddling but supports and welcomes musicians other than fiddlers. The image to the right side of the Fiddler's Rag name on the first page includes a mandolin, a banjo, a guitar and a fiddle, to illustrate the diversity of instruments played at our jams and events.



KAMIMOTO
STRING INSTRUMENTS

"Fiddles for Every Style..."

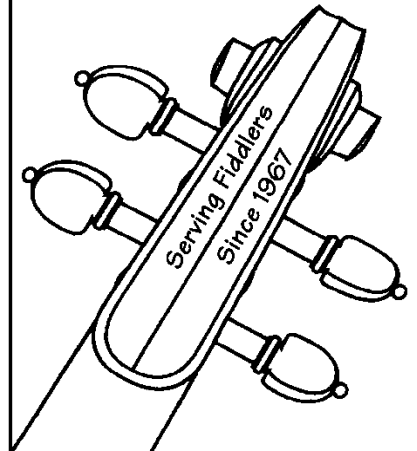

- New & Old Instruments
- Repairs & Restorations
- One-hour bow rehairing (by appt.)
- Rentals: Violin, Viola, Cello, Bass

Hours: Mon-Sat 10:00 - 5:30

[408] 298-8168
www.kamimotostrings.com

609 North Fourth Street
San Jose, CA 95112

[800] 892-3199

Fax: [408] 298-8198

SCVFA Happenings

SCVFA Mission Statement

Santa Clara Valley Fiddlers Association (SCVFA) preserves traditional music genres that feature fiddle and other acoustic instruments. SCVFA takes pride in “passing it on” to musicians and listeners of all ages and abilities.

Diversity Statement

SCVFA believes that our mission is fundamentally improved by diversity and inclusion. SCVFA is at all times committed to providing an open, safe, and welcoming environment for all our members and guests. We celebrate the varied abilities, ethnicities, sexualities, ages, gender identities, religions and cultural backgrounds of our community, and do not tolerate discrimination based upon these differences.

First Sunday Jam: March 1st 1:15 to 5:00 pm at Hoover Middle School. Suggested donation: \$5.00 – more or less as you are able. [Click here to donate online.](#)

Old-Time Jam: 1:15(ish) – 5 pm

Slow jam: 1:30-2:30 pm – Tunes are available [on the SCVFA website.](#)

Basic Bluegrass Jam: 1:30 – 3 pm led by Jennifer Kitchen. Songbook and more info are [on the SCVFA website.](#)

Bluegrass Jam: 1:30 – 5 pm led by Robert Cornelius.

“AFTERS” Join us at [Pasta Market](#) 579 Coleman Ave, San Jose.

3rd Sunday Jam: March 15th, 1-3 pm
[Municipal Rose Garden](#), San Jose.

[\(Mostly\) Old-Time Jam, Mondays, 7-9 pm.](#)

[Unitarian Universalist Church of Palo Alto.](#)

Requested donation – \$2 – \$4. Email [banjoelarka \[at\] yahoo.com](mailto:banjoelarka[at]yahoo.com) for more details.

[Bruce Molsky, March 5,](#) Santa Cruz house concert. Email [concerts \[at\] instantharmony.com](mailto:concerts[at]instantharmony.com). **March 6, 7:30 – 9:30 pm.** Concert at [Hillside Club](#), Berkeley.

[BOTMC Spring Situation, March 7, 1-5 pm.](#)

Concerts, jams, and workshops. [Berkeley Public Library.](#)

[The Corn Lickers, March 7, 1 pm.](#) Hosted old-time jam. [Berkeley Public Library.](#)

[Karen Celia Heil, March 7, 2 pm.](#) OT fiddle workshop. [Berkeley Public Library.](#) Free.

[CBA Spring Campout, April 14-19.](#) Lodi.

[Walker Creek Music Camp, April 23-26.](#) See link for instructors.

January Board Meeting Highlights:

By Jessica Ollmann, Secretary

More players have been joining our playouts, and over the past couple of months we have brought in \$1204.55 in payments and tips to support SCVFA.

Zakkai Melamed is moving on from his role as trustee after finishing his 3 year term.

Jennifer Kitchen has stepped up to take over the role of Vice President from Susan Goodis.

The board is eager to get feedback from members as to where we should invest our time and energy, so various polling and questionnaire options were discussed.

SCVFA remains committed to supporting bluegrass players and jams and will continue to experiment with how to bring players together and facilitate actual bluegrass jamming.

The Board is considering ways to promote old-time and bluegrass music in the South Bay area in addition to the monthly and park jams.

SCVFA at Great 48

By Susan Goodis

The Great 48 is a jamming festival put on by the California Bluegrass Association. For 4 days and 3 nights, pickers come from California and beyond to the Marriott Hotel in Bakersfield to jam 24x7 and listen to bands play in mini-concerts (often held in people's rooms). The normal hotel quiet hours are suspended on a few floors designated as "jamming floors." People on those floors can and do play around the clock, in the hallways, even outside the elevators.



Daytime jamming in the SCVFA hotel room

This year, Cata Fitzgerald and I (*see below*) hosted an old time jam room for SCVFA at The Great 48.

(continued on next page)



Susan Goodis and Cata Fitzgerald

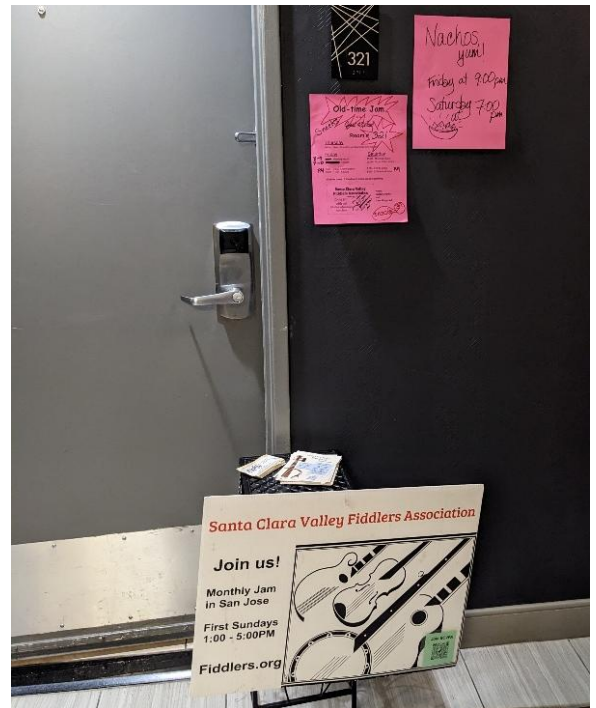

Advertising!!!



Nighttime jamming in the SCVFA hotel room



Bay Area Special performing in the CBA Suite – Elijah Chen, Ryan Triolo, Phil Cornish, Ruby Davis, Danny “Hootenanny” Clark (l-r)

We provided snacks and hosted more than 6 hours of jamming. We held ten one-hour long sessions from Thursday through Saturday for morning waltzes, A tunes, G tunes, D tunes, Celtic tunes, animal tunes and a couple of sessions for “anything goes”. We had up to 18 people in the room for the sessions. Every musician was given an SCVFA sticker and invited to visit when they come to the Bay Area. I do believe this was very successful.

Next year, we hope to see more SCVFA old-time musicians attend. You will have lots of good music to make the drive to Bakersfield well worthwhile. Or if you like to travel by train, there’s a jamming train that you can take from Berkeley to Bakersfield.

[Editor’s note: Lauren and I really wanted to go this year, but we couldn’t make it. Next year for sure!!]

Kelly O’Neill, along with his group from Fresno, also hosted another 2 hour old-time jam (*see below*).



Kelly O’Neill and friends from Fresno hosting an old-time jam

(President's Note – continued from page 1)

player was the bass player in AJ Lee and Blue Summit, so it was a great show, but that tells you that even the pros play the standards.

The songs will range from a slow to medium tempo – faster than the slow jam, but not playing at the ripping fast speeds that the hot bluegrassers can hit. Bringing tablets is encouraged, so you can reference the lyrics and chords. Jennifer will also have printouts available at the jam.

Our priority is to help you build a bluegrass repertoire at a pace and at tempos that are comfortable for you. If you learn these songs and learn how to play them in a traditional bluegrass style, you should be able to sit in on any bluegrass jam and be able to play and lead these songs, even if it's your first time there and you don't know a single person in that jam.

You'll also be able to play in small jams with other SCVFA members who've learned them, because you'll all know them. And of course, you'll be able to play them in larger SCVFA jams, like the bluegrass jam that Robert Cornelius leads.

I can hear the old-time players asking, "Why not do this for old-time?" I tried answering that question, and it turned into an answer that wasn't short. So I'll put that answer in next month's newsletter and instead, tell you what we want to do on the old-time side.

People want to add singing to the old-time jam. I love that idea. The Board loves that idea. The difference between jams out in California and the jams with locals that I've been at in the Southeast is that there's often singing at the jams in the Southeast. Some are fiddle tunes that we already play. We just need someone to sing. Others are tunes that we don't play that we might want to learn. The good news is that a number of these are shorter tunes. Some only have one part and can get pretty repetitive if someone doesn't sing.

What I'm going to do is put together something similar to a songbook. I'll put together lyrics and pointers to reference recordings so people can learn the melody and tune.

Unfortunately, good reference recording for old-time fiddle tunes with singing are harder to find for old-time than they are for bluegrass. I'll link to good recordings on the internet if I can find them. But some of the recordings will be my own – recordings from out-of-print commercial CDs or field recordings that I've made over the years.

It's likely that many of the commercial recordings that I post will be excerpts. They'll be long enough to learn the vocal melody (which can be different from the fiddle melody). But to make sure we don't run into issues with copyrights, I won't post full-length tunes unless the copyright holder is known to be generous to old-time musicians.

The non-commercial recordings are field recordings that I've made over the years, mostly at music camps. For those, I can post the full-length recordings.

Please do NOT share recordings with non-members. For the field recordings, while I'm sure the musicians would give me permission to share them with you so you can learn the tunes, that's very different from posting the recordings up on YouTube or some other public site for everyone to see. For the commercial recordings, neither SCVFA nor I not want to be responsible, directly or indirectly, for copyrighted recordings being posted to YouTube or some other public site without permission from the copyright holders.

The songbook for the Basic Bluegrass Jam is already on the website. A handful of [old-time tunes are already posted](#) and I'll post more when I can. Check the "Tunes" drop-down menu on the [SCVFA website \(fidders.org\)](#) for both!

That's it for now. Happy playing!!!



Longtime SCVFA stalwarts Pete Showman and Ann Whitesell at the February jam (by Ray Chen)

February Pictures

By Ray Chen and Susan Goodis

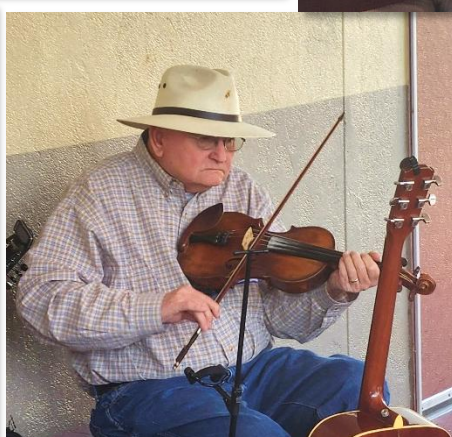



SCVFA
P.O. Box 390235
Mountain View, CA 94039-0235

The SCVFA Jam is held on the first Sunday of the month. Location: Hoover Middle School cafeteria and grounds. 1474 Naglee Ave., San Jose. The school is at the corner of Naglee and Park. Cafeteria parking is on the Naglee side.

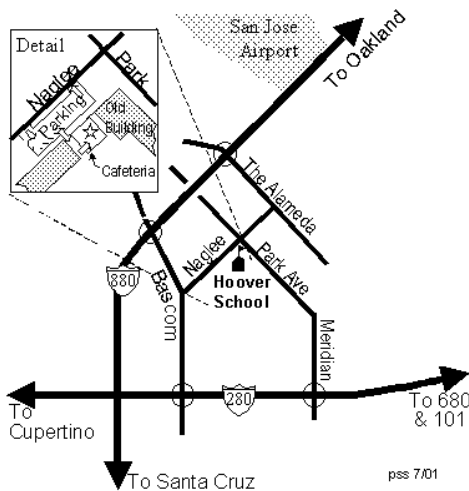

**Next Jam:
Sunday March 1st
1:15 – 5 pm at Hoover Middle
School**

See Map on the left and other info on pages 1 and 3

**Damaged or Missing Issue? Call us,
or email to: [newsletter \[at\] fiddlers.org](mailto:newsletter[at]fiddlers.org)**

**Overcoming: Songs, Stories, Drama
Sunday, March 22, 1 – 2 pm
[1041 Morse St., San Jose](https://www.google.com/maps/place/1041+Morse+St,+San+Jose,+CA+95128)**

A Benefit Performance Hosted by
[The San Jose Friends](https://www.google.com/maps/place/1041+Morse+St,+San+Jose,+CA+95128)

What: Friends from the hills of Kentucky and USSR's Ukraine join forces for toe-tapping theatrical and musical storytelling. Jointly named **Sweet Grits**, the duo's performance features songs and stories drawn from [Jody Yeary's](#) life and clinical practice as a therapist and [Nathan Ladyzhensky's](#) adventures and prodigious musical talents. (see picture at left)

Why: This is a benefit performance to make the historic 1885 Quaker (San Jose Friends) meeting house wheelchair accessible — and to have fun!

Tickets: \$23.18 at www.sweetgrits.eventbrite.com. Admission at the door is \$25 (cash preferred, checks & Zelle accepted) or what you can pay.

Sweet Grits: Singer, songwriter, and storyteller [Jody Yeary](#) shares tales drawn from her personal life and professional experience as a therapist, coach, and consultant. Jody's songs tell the story of her experiences personally and professionally. She sings about the sorrows and despair found in the troubled side of life. However, she believes there is hope even in the darkest hour. Her collaborator, [Nathan Ladyzhensky](#), a "recovering classical musician," arranges, composes, and plays a wide mix of styles and genres on multiple instruments. They combine their talents as the duo Sweet Grits.

Details at sanjosefriends.org/friends-perform. Learn more at sanjosefriends.org/140th. Email: sanjosequakers@gmail.com.

