



# Fiddler's Rag



Vol. 54, Number 04  
Celebrating 53 years

Santa Clara Valley Fiddlers Association  
[www.fiddlers.org](http://www.fiddlers.org)

April 2026  
Next Jam April 5<sup>th</sup>



## President's Note

By Ray Chen

Hello SCVFA!!

We've got some fun stuff lined up for the First Sunday Jams. Unfortunately, the next jam is one of those that happens to fall on a holiday – in this case, Easter Sunday. I know that's a challenge for some, but I hope you can make it! If not, we'll look forward to seeing you in May!

Jennifer reports that the March meeting of the Basic Bluegrass jam was well attended, and a lot of fun. We're working on a set of bluegrass standards that you can [find on our website](#). Take a look at the list, listen to the songs, and come to the jam and sing! All are welcome to join, and seasoned bluegrass players are welcome too!

Robert Cornelius has family commitments on Easter Sunday, so Robert has arranged for Banjer Dan to lead the Bluegrass Jam in his place. Thank you, Robert and Dan!

Matt Small will be leading an Intro to Western Swing Workshop at the April jam starting at 3 pm.

Matt tells me that Western swing is a subgenre of traditional country music that originated in the 1920s and 30s in the Southwest U.S. The music blends country, jazz, blues, polka, and big band swing. Sometimes referred to as "country jazz" or dance music with a Western flair, it often features improvisation and a strong, danceable beat. Bob Wills and His Texas Playboys are considered the most famous of the Western Swing bands.

Matt will introduce some of the concepts and common chord changes of Western Swing. So, come join him to learn more and share your experiences with this style of music. No prior experience required!

Matt will focus on four songs: "[New San Antonio Rose](#)" in G, "[All of Me](#)" in C, "I'm an Old Cowhand" in D, and one of his own compositions "Good Attitude" in G. Watch the videos if you want to study for the workshop or just come join the fun!

That's a lot going on in addition to the usual jamming, so we thought we'd try a "Singing with Old-Time Fiddle Tunes" workshop at the May jam.

The exact content is to be determined but I suspect we'll start with a fiddle tune most of us know and add the singing, rather than try to learn and sing a new tune all at the same time. My guess is we'll start with Sugar Hill, Rockingham Cindy, or Susannah Gal. Interestingly enough, Fly Around My Pretty Little Miss, Western Country, and Susannah Gal are typically thought of as three names for the same tune. It turns out that while the melodies are the same, they have different lyrics that are sung to the melody!

If you want to get a jump on the whole singing with fiddle tunes thing, you can look [here on our website](#).

Last, but not least, I want to thank Blane Eisenberg for volunteering to help with our website! I have high hopes that he'll help us get the website to what we want it to be. Thank you, Blane!!

Happy playing, everyone, and hope to see you at a jam sometime soon!

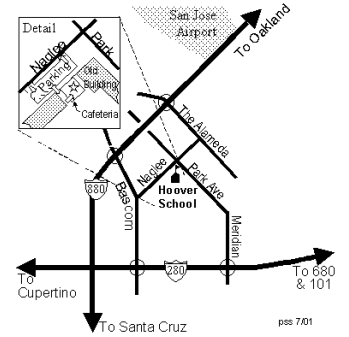

## Future Playouts / Performances

We have numerous opportunities throughout the year. For more info visit: <https://www.fiddlers.org/open-band>

**May 9<sup>th</sup>** – Our City Forest Spring Fest, 9 – 2 pm

**June 13<sup>th</sup>** – Morgan Hill Farmers Market, 9 – 1 pm

**June 21<sup>th</sup>** – San Jose Make Music Day, times TBD

## In This Issue:

## Page

President's Note .....	1
SCVFA Happenings.....	3
The Oddness of Old-Time by Ray Chen.....	4
Jam Photos by Ray Chen.....	5

The Fiddler's Rag is published monthly by the Santa Clara Valley Fiddlers Association and is provided to members of the Association. The Santa Clara Valley Fiddlers Association (SCVFA), founded in 1973 in San Jose, California, is a nonprofit, volunteer-operated organization dedicated to the preservation, teaching, and enjoyment of traditional music. Membership includes electronic delivery of the Fiddler's Rag.

To join, sign up at the jam or see [www.fiddlers.org/join-the-scvfa](http://www.fiddlers.org/join-the-scvfa)

### Officers and Chairs

President-Trustee .....	Ray Chen	News Editor / Publisher .....	Ray Chen
Vice President .....	Jennifer Kitchen	Performances .....	Susan Goodis
Secretary .....	Jessica Ollmann	Publicity .....	Susan Goodis
Treasurer .....	Bennett Amodio	Webmaster .....	Ray Chen
Membership Secretary .....	Cliff Riggs		

### Trustees

Seat 1: Jennifer Kitchen	Seat 3: Susan Goodis	Seat 5: Open
Seat 2: Michelle Tan	Seat 4: Open	Seat 6: Cliff Riggs

**Newsletter Reviewers:** Pete Showman, Dinah Showman, Vicki Parrish, Susan Goodis, Jennifer Kitchen

### To Contact the SCVFA:

Mail: SCVFA, P.O. Box 390235, Mountain View, CA 94039-0235

Email to Ray Chen: [president \[at\] fiddlers.org](mailto:president@fiddlers.org)

Jennifer Kitchen: [vp \[at\] fiddlers.org](mailto:vp@fiddlers.org)

Susan Goodis: [performances \[at\] fiddlers.org](mailto:performances@fiddlers.org)

**Newsletter Submissions & Comments:** [newsletter \[at\] fiddlers.org](mailto:newsletter@fiddlers.org)

**Address changes:** [membership \[at\] fiddlers.org](mailto:membership@fiddlers.org)

Website: [www.fiddlers.org](http://www.fiddlers.org)

Copyright 2026, Santa Clara Valley Fiddlers Association

The Santa Clara Valley Fiddlers Association is a non-profit member-supported organization.

**Donations** to SCVFA are greatly appreciated and will assist in keeping traditional music alive by passing it on to the next generation.

**Many local corporations offer matched donations for non-profits.** Check with your employer... they may offer this benefit.

You can easily add SCVFA as a 501(c)(3) organization; our EIN is 51-0196154

Donate as you are able and traditional music will reap the benefits.

-----

SCVFA was founded in 1973 to support fiddling but supports and welcomes musicians other than fiddlers. The image to the right side of the Fiddler's Rag name on the first page includes a mandolin, a banjo, a guitar and a fiddle, to illustrate the diversity of instruments played at our jams and events.



# KAMIMOTO

## STRING INSTRUMENTS

**"Fiddles for Every Style..."**

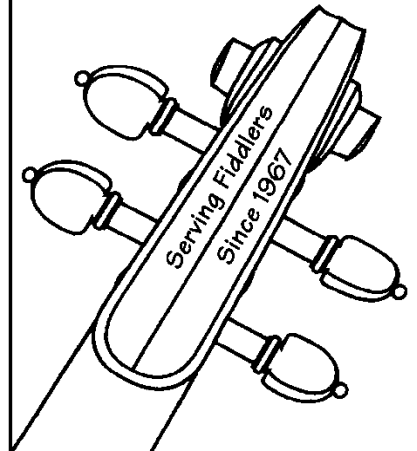

- New & Old Instruments
- Repairs & Restorations
- One-hour bow rehairing (by appt.)
- Rentals: Violin, Viola, Cello, Bass

Hours: Mon-Sat 10:00 - 5:30

**[408] 298-8168**

[www.kamimotostrings.com](http://www.kamimotostrings.com)

609 North Fourth Street  
San Jose, CA 95112

**[800] 892-3199**

**Fax: [408] 298-8198**

# SCVFA Happenings

## SCVFA Mission Statement

*Santa Clara Valley Fiddlers Association (SCVFA) preserves traditional music genres that feature fiddle and other acoustic instruments. SCVFA takes pride in “passing it on” to musicians and listeners of all ages and abilities.*

## Diversity Statement

*SCVFA believes that our mission is fundamentally improved by diversity and inclusion. SCVFA is at all times committed to providing an open, safe, and welcoming environment for all our members and guests. We celebrate the varied abilities, ethnicities, sexualities, ages, gender identities, religions and cultural backgrounds of our community, and do not tolerate discrimination based upon these differences.*

**First Sunday Jam: April 5<sup>th</sup>** 1:00 to 5:00 pm at Hoover Middle School. Suggested donation: \$5.00 – more or less as you are able. [Click here to donate online.](#)

**Old-Time Jam:** 1(ish) – 5 pm

**Slow jam:** 1:30-2:30 pm – Tunes are available on our [SCVFA website](#).

**Basic Bluegrass Jam:** 1:30 – 3:00 pm led by Jennifer Kitchen. Songbook and more info are [on the SCVFA website](#).

**Bluegrass Jam:** 1:30 – 5:00 pm led by Banjer Dan.

**Swing Jam** – 3 pm, led by Matt Small

“AFTERS” Join us at [Mountain Mike’s Pizza](#). 2011 Naglee Avenue, San Jose.

**3<sup>rd</sup> Sunday Jam: April 19<sup>th</sup>, 1-3 pm**  
[Mitchell Park](#), 600 E. Meadow Dr., Palo Alto

**[\(Mostly\) Old-Time Jam, Mondays, 7-9 pm.](#)**  
[Unitarian Universalist Church of Palo Alto.](#)  
Requested donation – \$2 – \$4. Email [banjoelarka \[at\] yahoo.com](mailto:banjoelarka@yahoo.com) for more details.

**[CBA Spring Campout, April 14-19.](#)** Lodi.

**[The Corn Likkers, April 18, 7-10 pm.](#)**  
[Monterey contra dance, YMCA of Monterey.](#)

**[Walker Creek Music Camp, April 23-26.](#)**  
Petaluma. See link for instructors.

**[Berkeley Bluegrass Festival, May 2-3.](#)** [The Freight.](#) ([Bay Area Special](#) in the lobby, May 3)

**[CBA Music Camp \(Grass Valley\): June 9 – 12.](#)** [Nevada County Fairgrounds](#), Grass Valley

**[CBA Father’s Day Festival \(Grass Valley\): June 13-16.](#)** [Nevada County Fairgrounds.](#)

## March Board Meeting Highlights:

*By Jessica Ollmann, Secretary*

President Ray Chen reported on new things we are trying with our regular and Basic Bluegrass jams.

Our membership management system still isn’t meeting all our needs, and website updates continue to be a focus.

We have made progress towards putting the majority of our funds into a money earning account, taking care to ensure that the money will be secure.

The board discussed whether we should assign leaders to jams, noting that the Old Time jam faltered in February when players left for the basic bluegrass jam.

Solutions were proposed to reduce the burden placed on the board member who serves as jam manager each month.

The board discussed what other programming SCVFA could sponsor, potentially offsite. The membership had expressed interest in a slow Old Time jam. SCVFA could pay someone to coordinate or lead jams outside of our usual times, but it wasn’t clear that that would benefit SCVFA. The board is open to exploring hosting more jams.

Our website could be used as a resource for finding opportunities in the traditional arts.



*March Old-Time (Ray Chen)*

## The Oddness of Old-Time

By Ray Chen

Last month, Jennifer Kitchen started the Basic Bluegrass Jam. The goal of that jam is, over time, to teach everyone a set of commonly played bluegrass tunes and teach people how to play them in a bluegrass style. People would then be able to take those tunes and play them at any bluegrass jam anywhere.

Unfortunately, this approach doesn't work in old-time. We old-time musicians wish it did. A commonly asked question of old-time fiddle teachers is, "Can you tell me what tunes I should learn so that I can jam with people?"

The challenge lies in the roots of the bluegrass and old-time repertoires and the way the tunes are played.

Bluegrass tunes tend to come from a common set of commercial recordings that are widely accessible. Old-time tunes come from a far larger set of recordings.

The core of bluegrass tunes is the chord progressions and if it's a song, the melody and lyrics that are sung. The core of old-time tunes is the melody played by the fiddle.

Bluegrass players don't need to know the melody to play a good break. Someone needs to know the melody to start the tune, but to play a solo, all you need to know is the chord structure, be able to play some kind of melody line over those chords, and a vague idea of what the melody is so you can reference that melody in what you play.

So if the lead can sing the song, someone (usually the lead) can play the melody to start the tune, and everyone plays the same chord progression, the song will work. Instrumental tunes are the same way, only there's no singing.

Old-time fiddle tunes are almost the exact opposite.

Old-time fiddle tunes are defined by the melody, not the chords. To make matters more challenging, most tunes have many versions with different melodies. Some of the melodies are so different, they're essentially different tunes.

Since everyone plays at the same time, people have to play the same (or at least compatible) melodies in addition to playing the same chords. If they don't and the melodies and/or chords clash, you get a mess instead of music.

So old-time players sort all this out on the fly. The fiddlers listen to each other and change what they

can to make the group sound good. The rhythm players listen to the fiddlers and adjust their chords and changes to fit the melody they hear. If the tune is too unfamiliar, a player may stop playing completely, rather than make a hash of things.

A lot of the version differences happen because much of the old-time repertoire comes not from commercial recordings, but from field recordings often made by (folk) revivalists scouring the countryside in search of every old-time fiddler they could find. These fiddlers were each the last link of a "telephone" game that could be hundreds of years old.

The telephone game is that game where someone says a message to another person, that person repeats the message to the next person in line, and so on, until the message reaches the last person in line. Invariably, the message changes along the way. Sometimes, the message is so different, it's almost or even completely unrecognizable from the original.

This is how old-time tunes were passed down. Many games of telephone played by countless numbers of people. But any person in a telephone chain might have spread their version of a tune to many people instead of just one. The many different games of telephone happening at the same time for many years is how you get who knows how many versions of "Lost Indian" with different melodies, with some that are in different keys, and with some having a different number of parts! But they all have the same name!

So what happens with old-time music is that different communities and sessions develop their own sets of tunes and versions that are commonly played and the sets change slowly over time. SCVFA has its set, many of which have been transcribed by Pete Showman. The jams at Marshall, NC, Pittsburgh, PA, or Tri-Cities, WA each have their own sets of tunes that are commonly played. Someone who knows every tune at one session may find when they drop into a different session that they know hardly any of the tunes played at the other session.

So an old-time teaching jam really can't teach you tunes that you can play in every old-time jam the way the Basic Bluegrass Jam can prepare you for bluegrass jams. Bluegrass players, count your blessings!

What you have to learn for old-time jams is how to fill your role well.

*(continued on page 6)*

# March Pictures

By Ray Chen

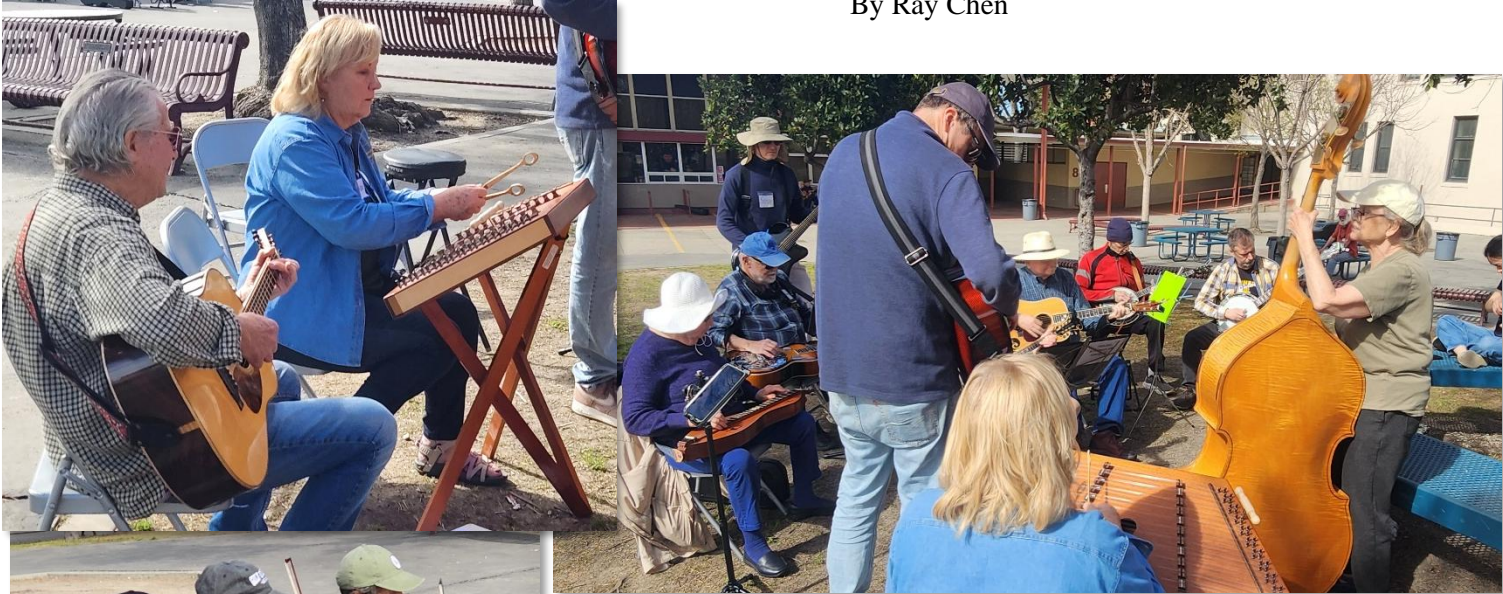



SCVFA  
 P.O. Box 390235  
 Mountain View, CA 94039-0235

**Next Jam:  
 Sunday April 5<sup>th</sup>  
 1:15 – 5 pm at Hoover Middle  
 School**

The SCVFA Jam usually on the first Sunday of each month.  
 Location: Hoover Middle School, 1474 Naglee Ave.,  
 San Jose. The school is at the corner of Naglee and Park.  
 Cafeteria parking is on the Naglee side.

**Damaged or Missing Issue? Call us,  
 or email to: [newsletter \[at\] fiddlers.org](mailto:newsletter@fiddlers.org)**

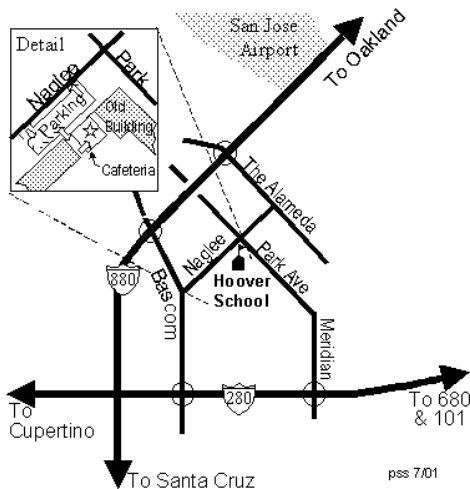

*(continued from page 4)*

For rhythm players, that means playing the chords and runs (or melody and chords if you're playing banjo) on time and in a way that helps keep the session energized and locked into the groove

For fiddlers and other lead instruments, if you're not sure that the other fiddlers know the version of the tune you're going to play, you need to pick something that's reasonably easy to follow, and play it clearly and at a steady tempo to make it easier for everyone else to follow you. It can be hard for people to help keep the session in a good groove when they're busy learning a new tune at the same time. So if you don't lead a tune that most people know, you also need to be ready to carry the tune yourself with little to no help from the rhythm and other lead players.

This sounds pretty intimidating. The good news is you don't need to do this well to be able to jam. Bigger jams tend to lock into a groove organically as long as people can hear each other and enough people can play at a steady tempo – especially if a lot of people in the jam know the same tunes. Where this stuff really starts to matter is smaller jams where there might only be one or two of each instrument. In any jam, but especially in a small jam, if a tune's not working, you can cut it short, declare it a trainwreck, and move onto the next tune. Most people are pretty understanding and will appreciate you cutting a shaky tune short.

Anyway, as I said last month, addressing this topic was going to be too long. And as usual, it turned out to be longer than I thought it was going to be!

I hope this was helpful or at least interesting.

See you at the next jam!!